

J E T

DDS225

DUAL DRUM SANDER

1791290T

400/50/3

**PARTS LIST
ERSATZTEILLISTE
LISTE DE PIECES**

WMH Tool Group AG

Bahnstrasse 24, CH – 8603 Schwerzenbach

www.wmhgroupool.ch; info@wmhtoolgroup.ch

Tel +41 (0) 44 806 47 48

Fax +41 (0) 44 806 47 58



P-1791290T 03/07s

PARTS LIST: Drum Assembly

Index No.	Part No.	Description	Size	Qty.
1	DDS225-101	Rear Drum		1
2	DDS225-102	Abrasive Fastener-Right		2
3	DDS225-103	Abrasive Fastener-Left		2
4	DDS225-104	Spring		2
5	DDS225-105	Locking Wedge		4
6	DDS225-106	Abrasive (80 Grit)		1
	DDS225-106A	Abrasive (100 Grit)		1
7	DDS225-107	Support Bracket		2
8	DDS225-108	Pulley		2
9	DDS225-109	Tension Roller		3
10	DDS225-110	Bushing		6
11	DDS225-111	Spring		6
12	DDS225-112	Bracket		6
13	DDS225-113	Bearing Assembly	UCFL205	4
14	VB-B68	Belt		2
15	DDS225-115	Key	8 x 7 x 50	2
16	DDS225-116	Adjusting Bushing		6
17	TS-0561031	Hex Nut	3/8-16	2
18	DDS225-118	Hex Cap Screw	5/16-18 x 5/8	12
19	TS-0720081	Lock Washer	5/16	12
20	TS-0060071	Hex Cap Screw	3/8-16 x 1-1/4	8
21	DDS225-121	Hex Cap Screw	1/2-13 x 1-1/2	4
22	TS-0720111	Lock Washer	1/2	8
23	DDS225-123	Hex Cap Screw	3/8-16 x 1-3/4	4
24	TS-0720091	Lock Washer	3/8	8
25	TS-1550071	Flat Washer	M10	4
26	TS-0207061	Socket Head Cap Screw	1/4-20 x 1	4
27	DDS225-127	Socket Set Screw	5/16-18 x 1/2	4
28	DDS225-128	Hex Cap Screw	3/8-16 x 3/4	4
29	TS-0060051	Hex Cap Screw	3/8-16 x 1	2
30	TS-0208021	Socket Head Cap Screw	5/16-18 x 1/2	4
31	TS-0270051	Socket Set Screw	5/16-18 x 1/2	2
32	DDS225-132	Spring		2
33	DDS225-133	Steel Ball	Ø1/4	2
34	DDS225-134	Socket Set Screw	1/4-20 x 1/4	4
35	DDS225-135	Adjusting Knob		2
36	DDS225-136	Lead Screw		2
37	TS-0207041	Socket Head Cap Screw	1/4-20 x 3/4	4
38	TS-0680061	Flat Washer	1/2	4
39	TS-0720071	Lock Washer	1/4	4
40	DDS225-140	Top Cover-Right		1
41	DDS225-141	Collar		2
42	DDS225-142	Slide		2
43	DDS225-143	Locking Lever		2
44	DDS225-144	Slide Bracket-Right		1
45	TS-0561011	Hex Nut	1/4-20	4
46	TS-0267091	Socket Set Screw	1/4-20 x 1	4
47	DDS225-147	Gib-Right		1
48	DDS225-148	Top Cover-Left		1

Index No.	Part No.	Description	Size	Qty.
49.....	TS-1541041.....	Hex Nylon Lock Nut.....	M10.....	6
50.....	DDS225-150.....	Adjusting Screw.....		6
51.....	DDS225-151.....	Hex Nut.....	M22 x 1.5P x 5T.....	6
52.....	DDS225-152.....	Slide Bracket-Left.....		1
53.....	DDS225-153.....	Gib-Left.....		1
54.....	DDS225-154.....	Front Drum.....		1
55.....	TS-1521021.....	Socket Set Screw.....	M4 x 10L.....	4
56.....	DDS225-156.....	Hex Cap Screw.....	1/2-13x 1-1/4.....	4
57.....	TS-0720091.....	Lock Washer.....	3/8.....	8
58.....	DDS225-158.....	Roll Pin.....	Ø2 x 8mm.....	2
59.....	DDS225-159.....	Pulley Guard.....		1
60.....	DDS225-160.....	Bracket.....		2
61.....	DDS225-161.....	Flat Washer.....	1/4".....	4
62.....	DDS225-162.....	Screw.....	1/4"-20 x 3/8.....	6

Drum Assembly

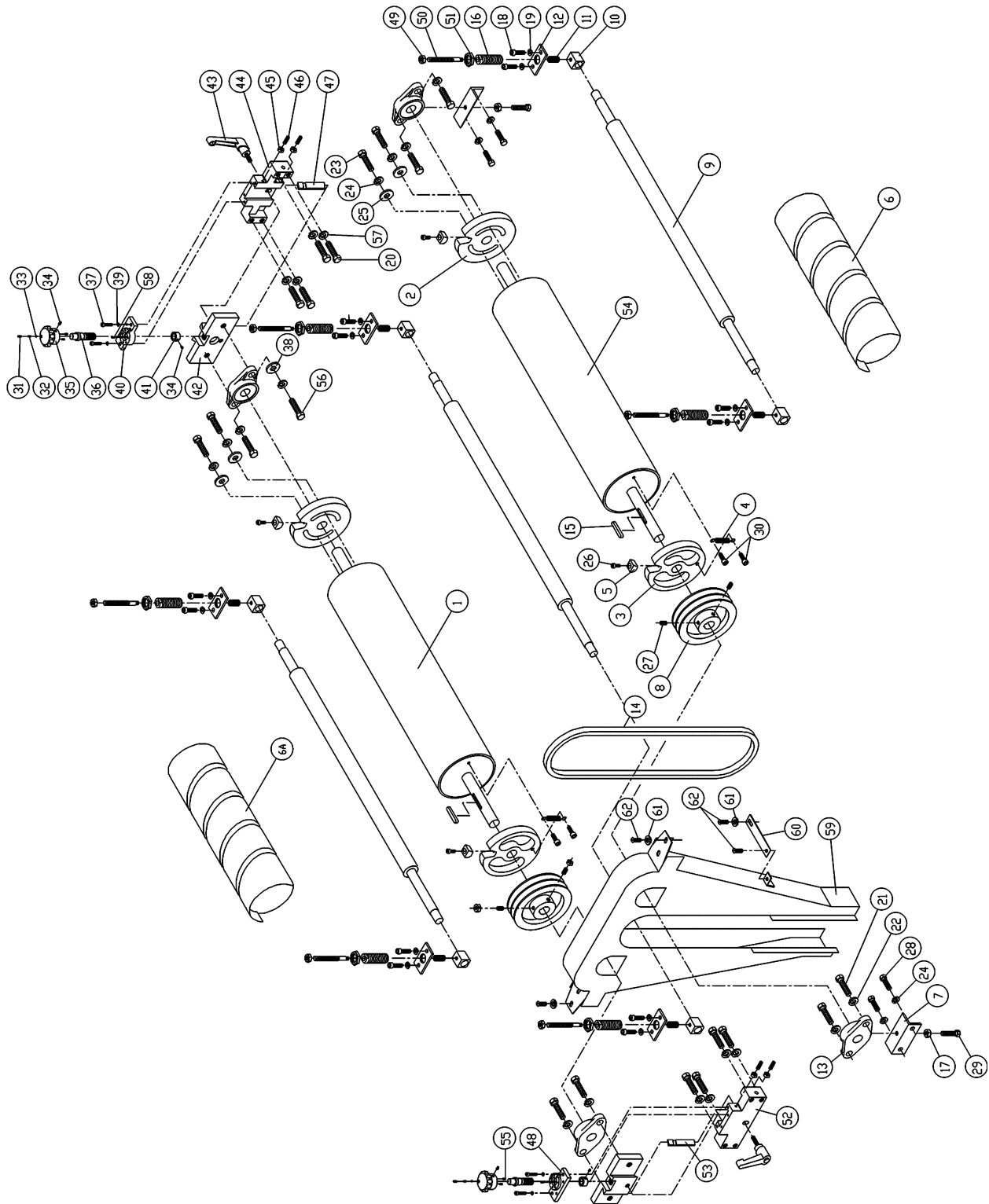

PARTS LIST: Conveyor Assembly

Index No.	Part No.	Description	Size	Qty.
1.....	DDS225-201.....	Table.....		1
2.....	DDS225-202.....	Support Bracket, Left-Front.....		1
3.....	DDS225-203.....	Support Bracket, Right-Front.....		1
4.....	DDS225-204.....	Support Bracket, Left-Rear.....		1
5.....	DDS225-205.....	Support Bracket, Right-Rear.....		1
6.....	DDS225-206.....	Leadscrew Holder, Right-Front.....		1
7.....	DDS225-207.....	Leadscrew Holder, Left-Front and Right-Rear.....		2
8.....	DDS225-208.....	Rod.....		1
9.....	DDS225-209.....	Front Roller.....		1
10.....	DDS225-210.....	Front Support Plate.....		1
11.....	DDS225-211.....	Collar.....		2
12.....	DDS225-212.....	Adjusting Knob.....		2
13.....	DDS225-213.....	Rear Roller.....		1
14.....	DDS225-214.....	Rear Support Plate.....		1
15.....	DDS225-215.....	Drive Leadscrew.....		1
16.....	DDS225-216.....	Driven Leadscrew.....		3
17.....	DDS225-217.....	Sprocket.....		4
18.....	DDS225-218.....	Support Bracket.....		8
19.....	DDS225-219.....	Guide Plate.....		2
20.....	DDS225-220.....	Post.....		1
21.....	DDS225-221.....	Handle.....		1
22.....	DDS225-222.....	Pointer.....		1
23.....	DDS225-223.....	Collar.....		2
24.....	DDS225-224.....	Bolt.....		1
25.....	BB-6203ZZ.....	Ball Bearing.....	6203ZZ.....	4
26.....	DDS225-226.....	Thrust Bearing.....		4
27.....	DDS225-227.....	Roll Pin.....	Ø6 x 25mm.....	1
28.....	DDS225-228.....	Chain.....		1
29.....	TS-081F022.....	Phillips Pan Head Machine Screw.....	1/4-20 x 3/8.....	1
30.....	TS-0050011.....	Hex Cap Screw.....	1/4-20 x 1/2.....	8
31.....	TS-0207111.....	Socket Head Cap Screw.....	1/4-20 x 2-1/4.....	16
32.....	TS-0720071.....	Lock Washer.....	1/4.....	16
33.....	TS-0561082.....	Hex Nut.....	3/4-16UNF.....	8
34.....	DDS225-234.....	Key.....	5 x 5 x 18mm.....	4
35.....	DDS225-235.....	Socket Head Cap Screw.....	5/16-18 x 3/4.....	16
36.....	TS-0720081.....	Lock Washer.....	5/16.....	22
39.....	TS-1550061.....	Flat Washer.....	M8.....	16
40.....	TS-0571082.....	Hex Jam Nut.....	3/4-16UNF.....	4
41.....	DDS225-241.....	Conveyor.....		1
42.....	TS-0561031.....	Hex Nut.....	3/8-16.....	1
43.....	DDS225-243.....	Front Cover.....		1
44.....	DDS225-244.....	Rear Cover.....		1
45.....	DDS225-245.....	Threaded Bushing.....		4
46.....	DDS225-246.....	Handwheel.....		1
47.....	DDS225-247.....	Socket Set Screw.....	5/16-18 x 1/2.....	2
48.....	DDS225-248.....	Leadscrew Holder, Left-Rear.....		1
49.....	TS-0208041.....	Socket Head Cap Screw.....	5/16-18 x 3/4.....	6
50.....	TS-1550061.....	Flat Washer.....	5/16.....	12

Index No.	Part No.	Description	Size	Qty.
51	TS-0720081	Lock Washer	5/16	6
52	TS-0640081	Hex Nut	5/16-18	6
53	TS-0208021	Socket Head Cap Screw	5/16-18 x 1/2	6
54	DDS225-254	Hex Nut	1/4-20	8
55	TS-0050081	Hex Head Screw	1/4-20 x1-3/4	8
56	DDS225-256	Shield		1
57	TS-0680021	Flat Washer	1/4	2
58	DDS225-258	Screw	1/4-20 x1/4	2
59	DDS237-259	Upper Bracket		4
60	DDS237-260	Boot	1/4-20 x1/4	4
61	TS-081C022	Screw	#10-24x3/8	8
62	TS-0680011	Flat Washer	3/16	8
63	DDS237-257	lower Bracket		4
64	DDS237-258	Special Washer		4
65	DDS225-336	Hex Head Screw	1/4-20 x3/8	8
66	DDS237-266	Special Washer		4
67	TS-0267051	Set Screw	1/4-20x1/2	4

Conveyor Assembly

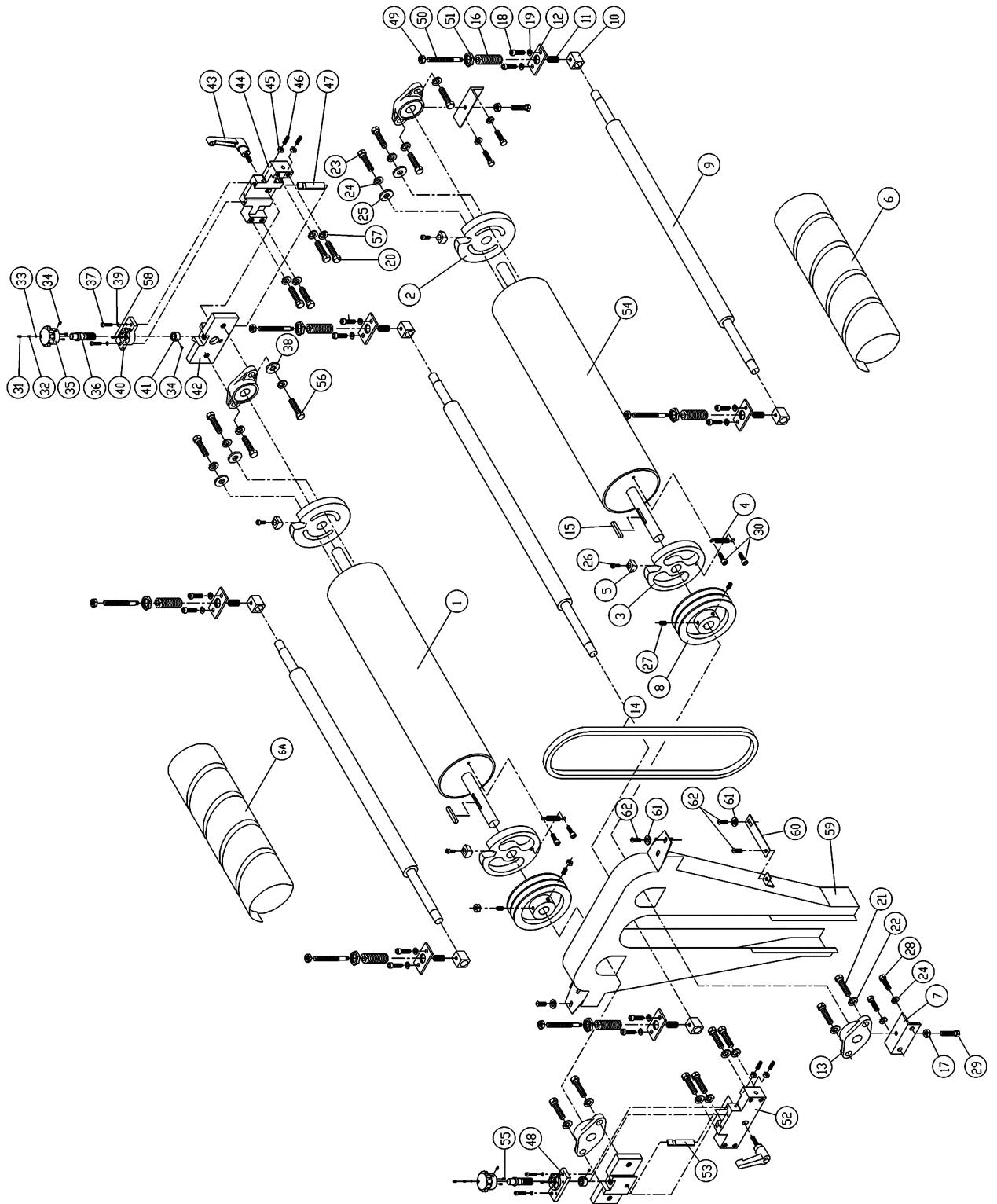

PARTS LIST: Motor & Cabinet Assembly

Index No.	Part No.	Description	Size	Qty.
1	DDS225-301	Cabinet		1
2	DDS225-302	Support Bracket-Front		1
3	DDS225-303	Support Bracket-Rear		1
4	DDS225-304	Motor Plate		1
5	DDS225-305	Motor Pulley		1
6	DDS225-306AE	Motor	5HP, 3Ph, 400V	1
7	DDS225-307	Adjusting Screw		2
8	DDS225-308	Hinge		2
9	DDS225-309	Fixed Block		1
10	DDS225-310	Cylinder		1
11	DDS225-311	Flow Deflector		1
12	DDS225-312	Top Cover		1
13	DDS225-313	Dust Chute		2
14	DDS225-314	Roller Holder		1
15	DDS225-315	Idle Roller		1
16	DDS225-316	Switch Bracket		1
17	DDS225-317	Direction Label		1
18	DDS225-318E	Scale		1
19	DDS225-319	Spacer		1
20	DDS225-320	Door Latch		3
21	DDS225-321	Handle		1
22	DDS225-322AE	Magnetic Switch		1
23	DDS225-323AE	Power Cord		1
24	DDS225-324AE	Strain Relief		4
25	DDS225-325	Key	5 x 5 x55 mm	1
26	DDS225-326	Screw	3/16-24 x 1/2	18
27	TS-0720051	Lock Washer	#10	2
28	DDS225-328	Socket Head Cap Screw	3/8-16 x 3/4	6
29	TS-0720091	Lock Washer	3/8	10
30	TS-1550071	Flat Washer	M10	4
31	DDS225-313	Socket Head Cap Screw	M8 x25	1
32	TS-0207021	Socket Head Cap Screw	1/4-20 x 1/2	1
33	TS-0720071	Lock Washer	1/4	21
34	DDS225-334	Shoulder Screw	M8 X1.25P X11	1
35	DDS225-335	Hex Nylon Lock Nut	M8	2
36	DDS225-336	Hex Head Screw	1/4-20 X 1/2	6
37	TS-0680021	Flat Washer	1/4	16
38	TS-0050011	Hex Cap Screw	1/4-20 x 1/2	6
39	TS-0208041	Socket Head Cap Screw	5/16-18 x 3/4	2
40	TS-0561021	Hex Nut	5/16-18	2
41	DDS225-341	Socket Head Cap Screw	5/16-18 x 1	1
42	DDS225-342	Flat Washer	M8	1
43	DDS225-343	Socket Set Screw	5/16-18 x 1/2	2
44	TS-0561031	Hex Nut	3/8-16NC	10
45	DDS225-345	Hex Cap Screw	3/8-16NC x 1-1/2	4
46	DDS225-346	Shoulder Screw		1
47	TS-0208061	Hex Cap Screw	5/16-18 x 1	1
48	TS-081F032	Phillips Pan Head Machine Screw	1/4-20 x 1/2	4
50	DDS225-350	Label (Drum Setting Gauge)		2
51	DDS225-351	Flat Washer	5/16	1

Index No.	Part No.	Description	Size	Qty.
52.....	DDS225-352.....	Flat Washer	3/8.....	8
53.....	DDS225-353.....	Strain Relief		2
54.....	DDS225-354AE.....	Motor Cord		1
55.....	DDS225-355.....	Front Cover		1
56.....	TS-1550031.....	Flat Washer	3/16.....	26
58.....	DDS225-358.....	Screw	3/16-24 x 3/8.....	14
59.....	DDS225-359.....	Rear Cover		1
60.....	DDS225-360.....	Self Tapping Screw.....	1/4 x 1/2.....	2
61.....	TS-069204.....	Flat Washer	SAE #10	2
62.....	DDS225-362.....	Lock Piece		2
63.....	DDS225-363.....	Plastic Nut.....		2
64.....	DDS225-364.....	Lock Housing		2
65.....	DDS225-365.....	Lock Knob		2
66.....	DDS225-366.....	Scoket Head Cap Screw	1/4-20x 1/2.....	4
67.....	TS-0720071.....	Lock Washer.....	1/4.....	4
68.....	DDS225-368.....	Holder		2
69.....	DDS225-369.....	Plate.....		1
70.....	TS-1490111.....	Hex Cap Screw.....	M8 x 60.....	2
71.....	DDS225-371.....	Flat Washer	M8.....	2
72.....	DDS225-372.....	Spring.....		2
73.....	TS-1540061.....	Hex Nut.....	M8.....	2
74.....	TS-081F022	Phillips Pan Head Machine Screw.....	1/4-20 x 5/16.....	4
75.....	DDS225-375.....	Screw	3/16-24 x 1-1/4	2
76.....	DDS225-376.....	Limit Switch.....		1
77.....	DDS225-377.....	Cord Holder		2
78.....	DDS225-378AE.....	Cord, Limit Switch.....		1
79.....	DDS225-379AE.....	Switch Cord, Mag Switch to Power Switch.....		1
82.....	DDS225-382AE.....	Power Switch		1
84.....	DDS225-384.....	Top Cover Warning Label (Not Shown)		1
85.....	DDS225-385.....	JET Logo		1
86.....	DDS225-386.....	I.D. Label.....		1
87.....	TS-0720081.....	Lock Washer.....	5/16	1
88.....	DDS225-388.....	Table Warning Label (Not Shown)		2
89.....	DDS225-389.....	Plug for Power Cord		1
90.....	DDS225-390.....	Running Direction Label (Not Shown)		1
91.....	DDS225-391.....	Switch Lock.....		1
92.....	DDS225-392.....	Pad.....		4

Motor & Cabinet Assembly

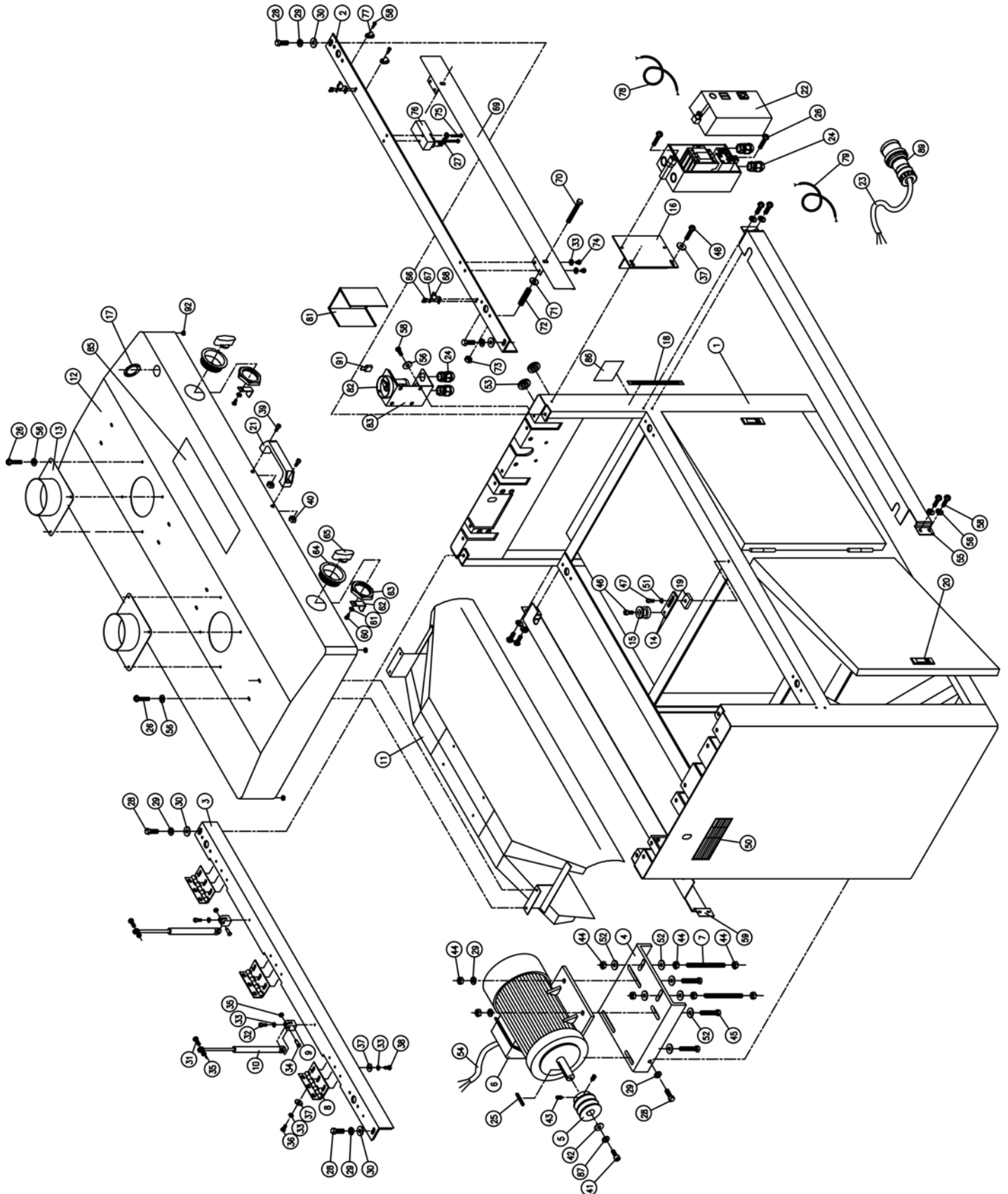

PARTS LIST: Gearbox Assembly

Index No.	Part No.	Description	Size	Qty.
1.....	DDS225-401.....	Gearbox Body.....		1
2.....	TS-0720071.....	Lock Washer.....	1/4.....	4
3.....	TS-0207071.....	Socket Head Cap Screw.....	1/4-20 x 1-1/4.....	4
4.....	DDS225-404.....	Drain Plug.....		1
5.....	BB-626VV.....	Ball Bearing.....		2
6.....	DDS225-406.....	Gear.....	66T.....	1
7.....	DDS225-407.....	Key.....	4 x 4 x 8.....	1
8.....	DDS225-408.....	Pinion.....		1
9.....	BB-6000VV.....	Ball Bearing.....	6000VV.....	1
10.....	DDS225-410.....	C-Ring.....		1
11.....	DDS225-411.....	Gear.....	70T.....	1
12.....	DDS225-412.....	Gear.....	57T.....	1
13.....	DDS225-413.....	Shaft.....		1
14.....	BB-6002VV.....	Ball Bearing.....	6002VV.....	2
15.....	DDS225-415.....	Key.....	5 x 5 x 20.....	1
16.....	DDS225-416.....	Shaft.....		1
17.....	DDS225-417.....	Cover.....		1
18.....	TS-1503041.....	Socket Head Cap Screw.....	M6 x 16.....	9
19.....	DDS225-419.....	Key.....	5 x 5 x 30.....	1
20.....	DDS225-420.....	Collar.....		1
21.....	DDS225-421.....	Oil Plug.....		1
22.....	DDS225-422.....	Handle.....		1
23.....	BB-6006VV.....	Ball Bearing.....		1
24.....	DDS225-424.....	C-Ring.....		1
25.....	DDS225-425.....	Gear.....	64T.....	1
26.....	DDS225-426.....	Key.....	8 x 8 x 15.....	1
27.....	DDS225-427.....	Block.....		1
29.....	DDS225-429.....	Gear.....	77T.....	1
30.....	DDS225-430.....	Key.....	6 x 6 x 50.....	1
31.....	DDS225-431AE.....	Cable.....		1
32.....	DDS225-432AE.....	Motor.....	1/4HP, 3PH, 400V.....	1
33.....	DDS225-433.....	Gasket.....		2
34.....	DDS225-434.....	Steel Ball.....		1
35.....	DDS225-435.....	Spring.....		1
36.....	TS-1523011.....	Socket Set Screw.....	M6 x 6.....	1

Gearbox Assembly

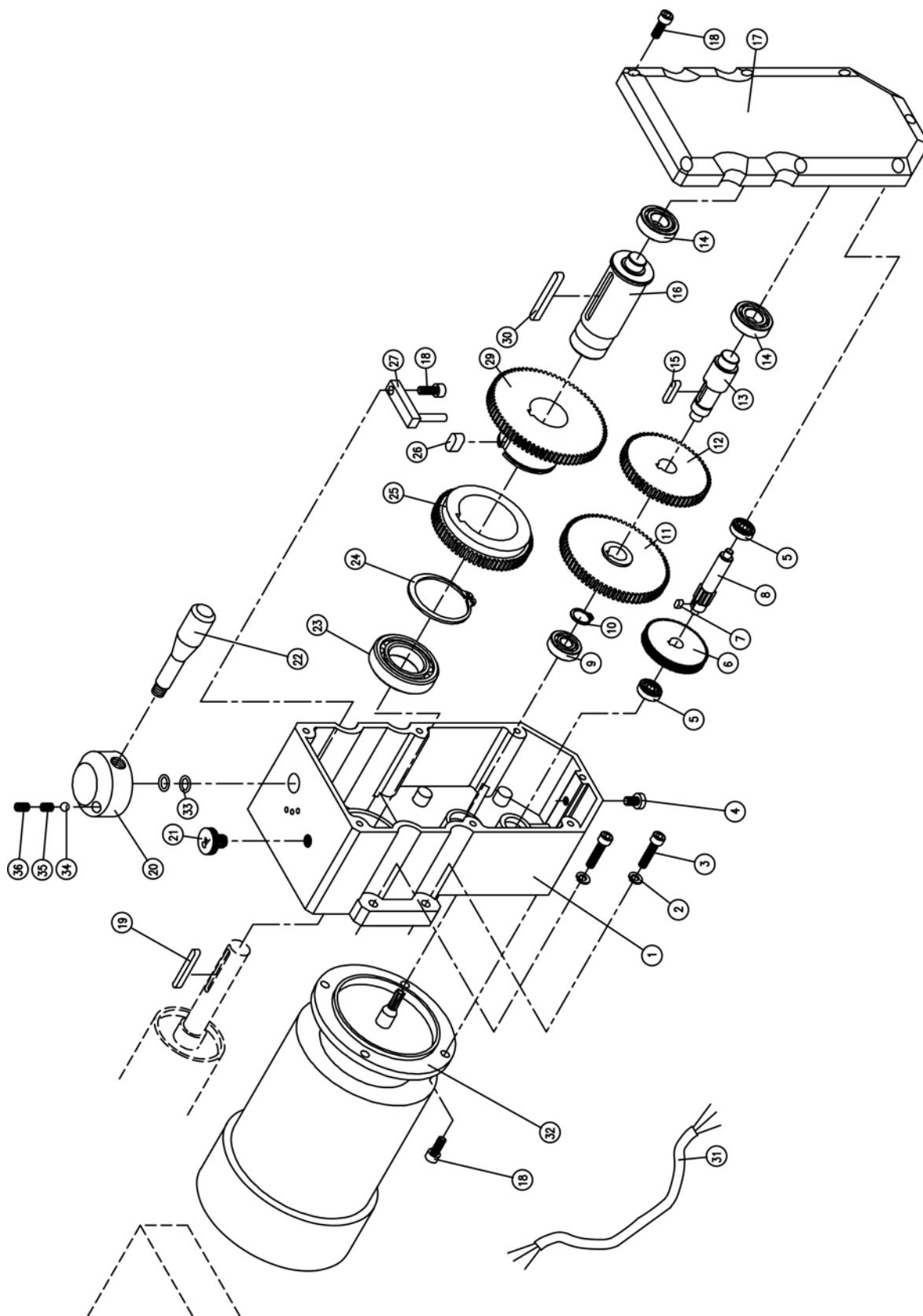

DDS225
1791290T

400/50/3

	colour of strands	Litzenfarben	couleur des cordons
BK	black	schwarz	noir
WH	white	weiß	blanc
BU	blue	blau	bleu
YE	yellow	gelb	jaune
RD	red	rot	rouge
BN	brown	braun	brun
GY	grey	grau	gris
GNYE	green-yellow	grün-gelb	vert-jaune
OG	orange	orange	orange
VT	violet	violett	violet

	meaning of symbol	Bedeutung der Zeichen	interprétation
M	motor	Motor	moteur
S	switch	Schalter	interrupteur
C	condenser	Kondensator	condensateur
E	electronic unit	Elektronik Einheit	unité électronique
F	fuse	Sicherung	fusible
RS	reversing switch	Drehrichtungsschalter	commu. droite/gauche
CS	centrifugal switch	Fliehkraftschalter	déclencheur centrifuge
OL	overload cut-off	Überlastschuttschalter	déclencheur surcharge
LS	limit switch	Positionsendschalter	micro

